
Annex no. 1

Assembly instructions

Container stairs



.....
(Prepared by)

.....
(Checked by)

.....
(Approved by)

.....
(Signature)

.....
(Signature)

.....
(Signature)

Table of contents

1.	Assembly instructions	4
2.	Components of the container stairs system.	8
3.	Tools necessary for installation of container stairs	17
4.	Assembly operations with individual elements of the container stairs system.....	18
4.1.	Assembly: supports	19
4.2.	Assembly of landings	20
4.3.	Assembly: posts	22
4.4.	Assembly: stairs	25
4.5.	Assembly: LP connector	27
4.6.	Assembly: LP2/LP3 connector	28
4.7.	Assembly: barriers	29

Item	NAME AND SURNAME	DEPARTMENT	DATE OF CHANGE	SCOPE OF REVISION	NOTES
1					
2					
3					
4					
5					
6					
7					
8					
9					
10					
11					
12					
13					
14					
15					

1. Assembly instructions

The assembly instructions constitute the annex to the operational and maintenance manuals of the container stairs system.

The container stairs consist of individual elements, as listed in the specification enclosed with the delivery. There are bolted connections and pins in the system. The system is supplied in the form of separate elements, such as platforms, barriers, steps, connectors, stairs and poles. The elements are installed in the specified order.

The container stairs, as a modular structure, may be freely configured as needed. Setting of the individual configuration should be compliant with the operating and maintenance manuals. The following are 7 basic arrangements of the container stairs.

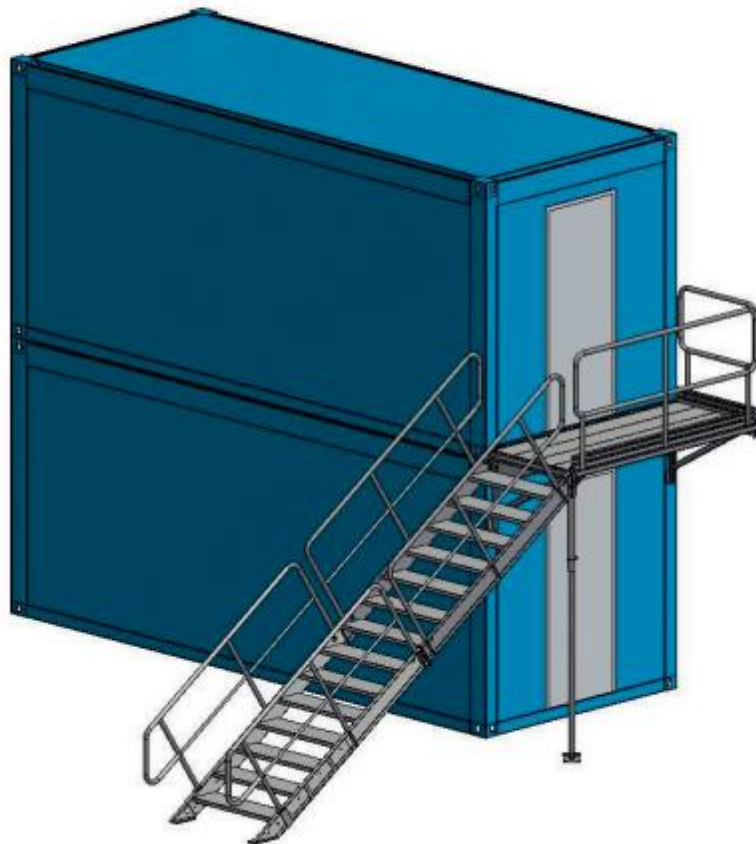


Figure 1. Configuration 1

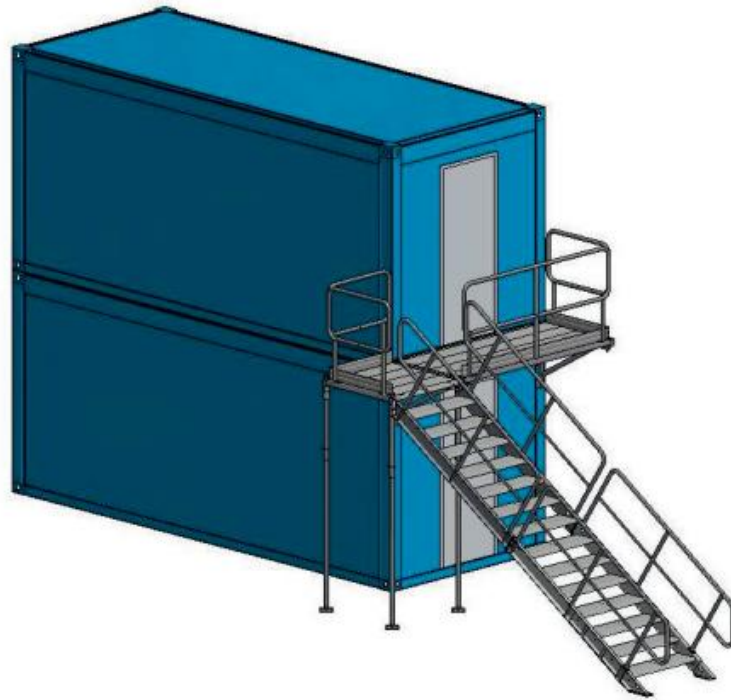


Figure 2. Configuration 2

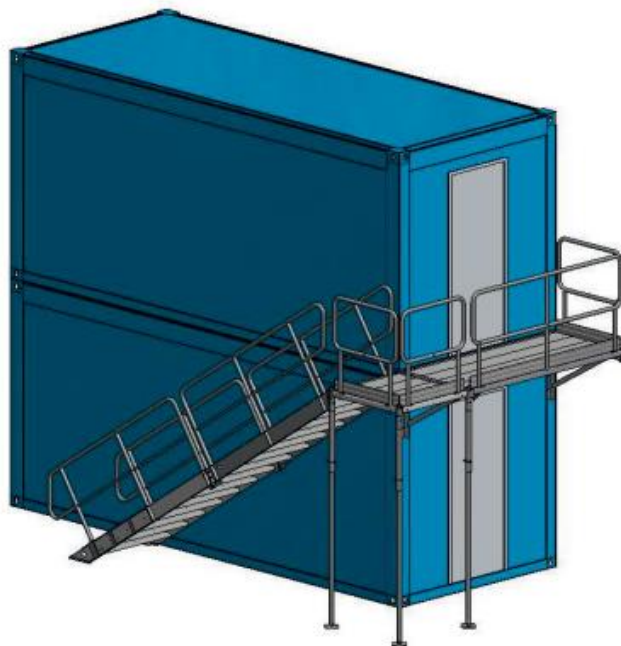


Figure 3. Configuration 3

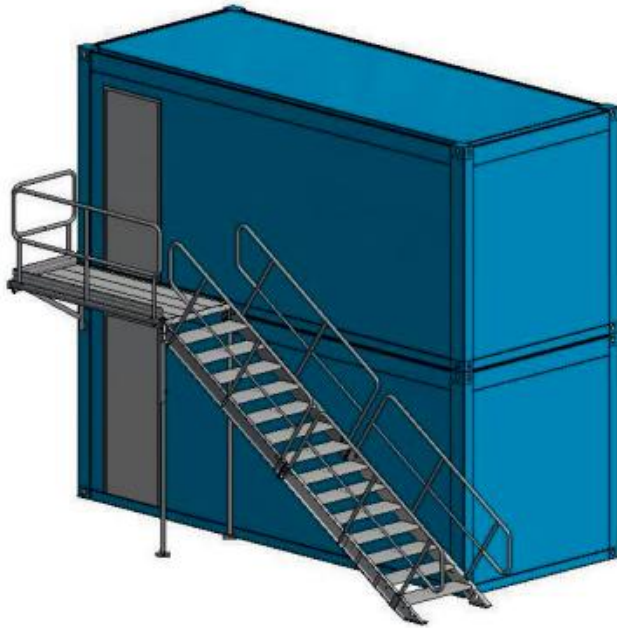


Figure 4. Configuration 4

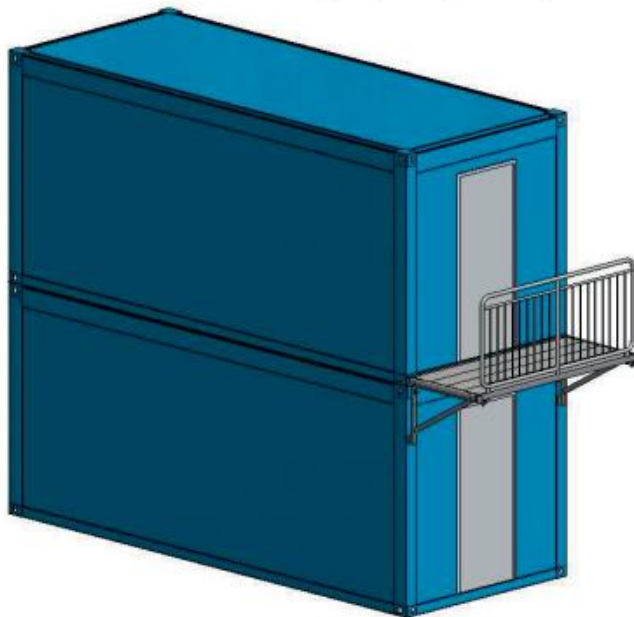


Figure 5. Configuration 5

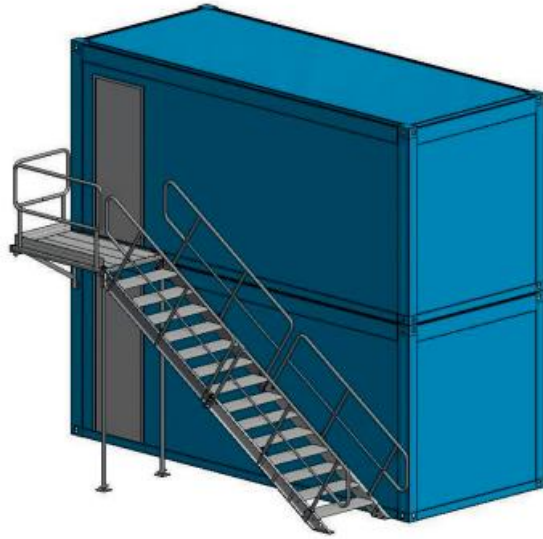


Figure 6. Configuration 6

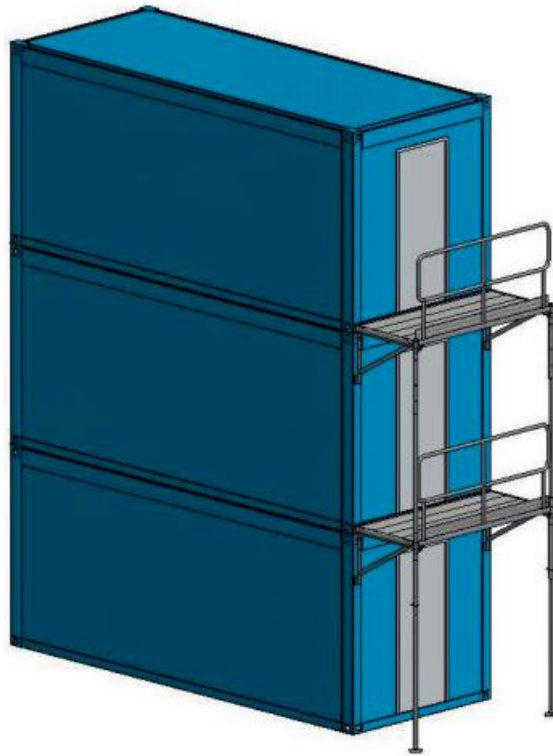


Figure 7. Configuration 7

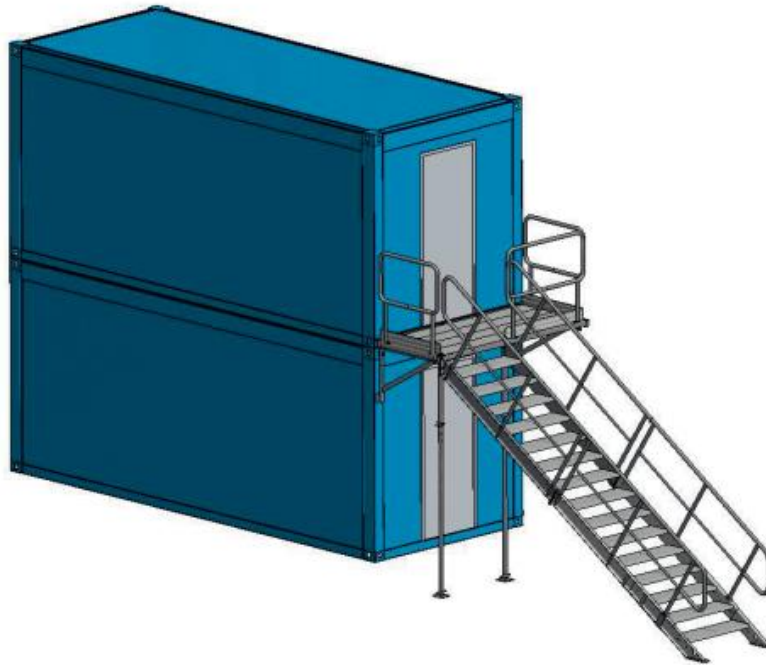


Figure 8. Configuration 8

2. Components of the container stairs system.

The list of elements in Table 1 presents the components of the container stairs system and their quantity installed, depending on the configuration, and the type of the system ordered by the client (to be selected from the column of marking, description of the element).

Table 1. The list of parts

Item	Code	Description of component	Configuration							
			1	2	3	4	5	6	7	8
Components of the container stairs system										
1	P-SK5-SB-FG1.1	Stairs module 1100 top	1	1	1	1	0	1	0	1
	P-SK5-SB-FG1.2	Stairs module 1200 top								
2	P-SK5-SB-FD1.1	Stairs module 1100 bottom	1	1	1	1	0	1	0	1
	P-SK5-SB-FD1.2	Stairs module 1200 bottom								
3	P-SK5-SB-FR1.1/A	Stairs foot left	1	1	1	1	0	1	0	1
4	P-SK5-SB-FR1.1/B	Stairs foot right	1	1	1	1	0	1	0	1
5	P-SK5-PD1.1	Landing 1100x1100	0	1	1	0	0	0	0	0
	P-SK5-PD1.2	Landing 1200x1200								
6	P-SK5-PD2.4	Landing 2440x1100	1	1	1	1	1	0	1	0
	P-SK5-PD2.4-1.2	Landing 2440x1200								
6a	P-SK5-PD2.4	Landing 2440x1100	0	0	0	0	0	0	0	1
	P-SK5-PD2.4-1.2	Landing 2440x1200								
7	P-SK5-PD1.6g	Landing 1690x1100	0	0	0	0	0	1	0	0
	P-SK5-PD1.6gx1.2	Landing 1690x1200								
8	P-SK5-WT1.1	Landing support 1100	2	2	2	1	2	1	4	2
	P-SK5-WT-1100-ML P-SK5-WT-1100-MP	Complete set of landing supports 1100 left + right for sea containers	1	1	1	1	1	1	2	1
	P-SK5-WT1.2	Landing support 1200	2	2	2	1	2	1	4	2
9	P-SK5-WT-1200-ML P-SK5-WT-1200-MP	Complete set of landing supports 1200 left + right for sea containers	1	1	1	1	1	1	2	1
	P-SK5-PR	Pole 01	1	3	3	1	0	1	2	2
11	P-SK5-PR2	Pole 02	0	0	0	0	0	0	2	0
12	P-SK5-BS-1	Stairs barrier 01 heavy-duty	2	2	2	2	0	2	0	1
	P-SK5-BS-B-1	Stairs barrier 01 safe								
13	P-SK5-BS-2	Stairs barrier 02 heavy-duty	2	2	2	2	0	2	0	1
	P-SK5-BS-B-2	Stairs barrier 02 safe								
14	P-SK5-BP1.1	Landing barrier 1100x1100 heavy-duty	1	3	3	1	0	1	0	2
	P-SK5-BP1.1-B	Landing barrier 1100x1100 safe								
	P-SK5-BP1.2	Landing barrier 1200x1200 heavy-duty								
	P-SK5-BP1.2-B	Landing barrier 1200x1200 safe								
15	P-SK5-BP2.4	Landing barrier 2440 heavy-duty	1	1	1	1	1	0	1	1
	P-SK5-BP2.4-B	Landing barrier 2440 safe								
16	P-SK5-BP1.6g	Landing barrier 1690 heavy-duty	0	0	0	0	0	1	0	0
	P-SK5-BP1.6g-B	Landing barrier 1690 safe								
17	P-SK5-LP	Connector LP1	1	2	2	1	1	1	2	1
18	P-SK5-LP2/P-SK5-LP3	Connector LP2/LP3	0	0	0	1	0	1	0	0
19	ZW	Support clamp	2	2	2	1	2	1	4	2
20	P-SK5-PK	Pad PK	4	8	8	2	8	2	10	2
21	P-SK5-BP1.28	Landing barrier 1280 heavy-duty	0	0	0	0	0	0	0	1
	P-SK5-BP1.28-B	Landing barrier 1280 safe								
22	P-SK5-BP1.04	Landing barrier 1040 heavy-duty	0	0	0	0	0	0	0	1
	P-SK5-BP1.04-B	Landing barrier 1040 safe								

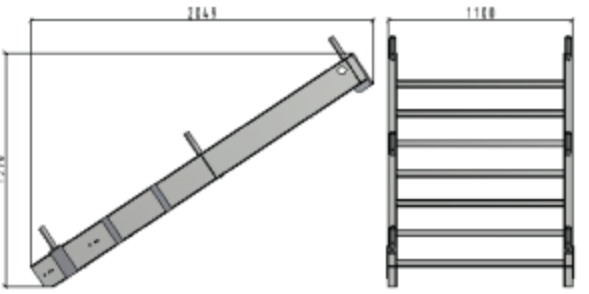
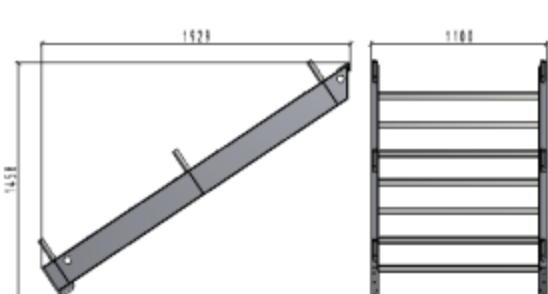
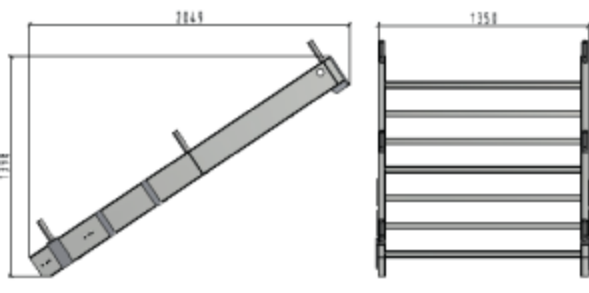
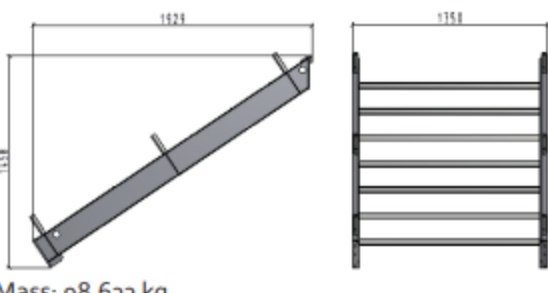
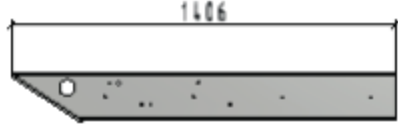
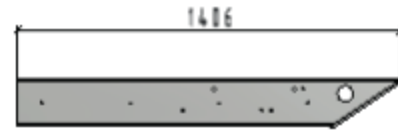
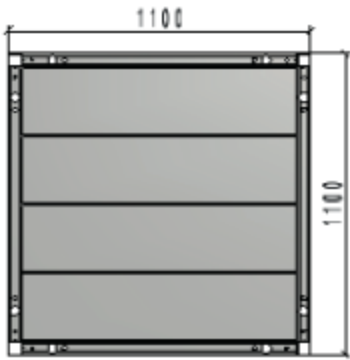
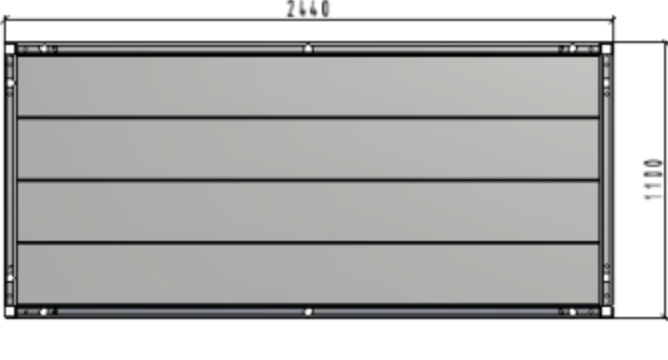
Table 2. Fasteners

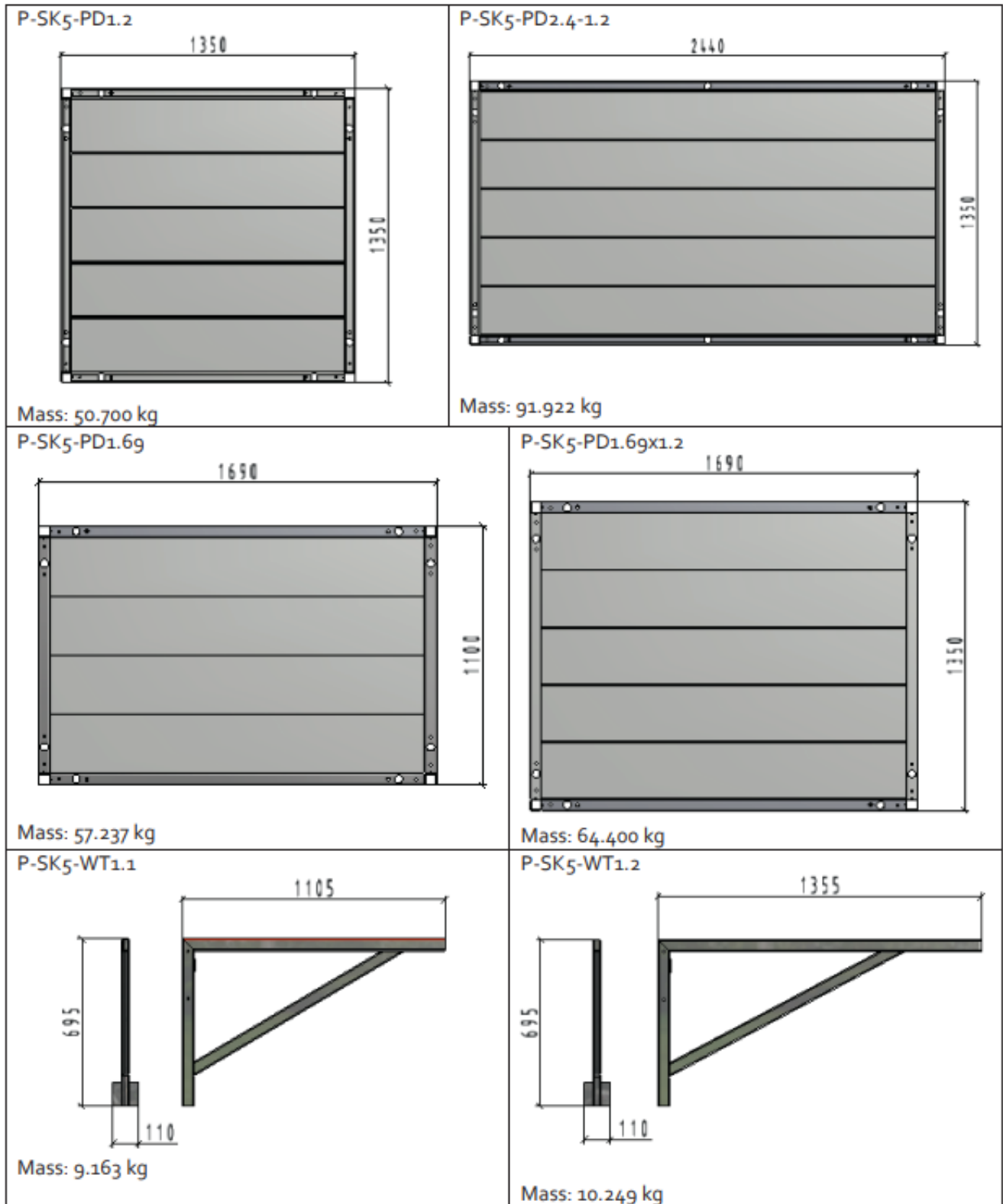
Item	Code	Description of component	Configuration							
			1	2	3	4	5	6	7	8
Fasteners										
A	ISO 4014-M10x25	Bolt M10x25 8.8	4	4	4	4	0	4	0	4
B	ISO 4014-M10x80	Bolt M10x80 8.8	5	10	10	6	0	6	4	6
C	ISO 4014-M10x65	Bolt M10x65 8.8	2	4	4	2	4	2	4	2
D	ISO 4014-M10x90	Bolt M10x90 8.8	1	0	0	1	1	1	2	1
E	ISO 4014-M10x120	Bolt M10x120 8.8	0	1	0	0	0	0	0	0
F	ISO 4014-M10x140	Bolt M10x140 8.8	2	4	4	1	2	1	4	1
G	ISO 4014-M12x45	Bolt M12x45 8.8	6	6	6	6	0	6	0	6
H	ISO 4032-M10	Nut M10	15	23	23	16	7	16	14	16
I	ISO 4032-M12	Nut M12	6	6	6	6	0	6	0	6
J	ISO 4032-M14	Nut M14	2	2	2	1	2	1	4	1
K	ISO 7089-M10	Washer 10	30	56	56	32	14	32	24	32
L	ISO 7089-M12	Washer 12	12	12	12	12	0	12	0	12
M	ISO 7089-M14	Washer 14	2	2	2	1	2	1	4	1
N	ISO 4014-M6x60	Bolt M6x60 8.8	4	4	4	4	0	4	0	4
O	ISO 4032-M6	Nut M6	4	4	4	4	0	4	0	4
P	ISO 4014-M8x25	Bolt M8x25 8.8	2	2	2	2	2	2	0	2
Q	ISO 4032-M8	Nut M8	2	2	2	2	2	2	0	2
R	ISO 7089-M8	Washer 8	4	4	4	4	4	4	0	4

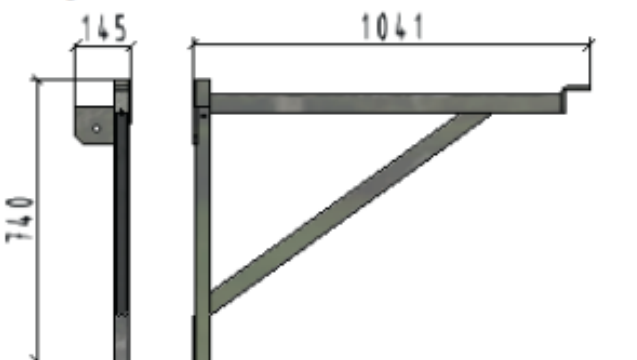
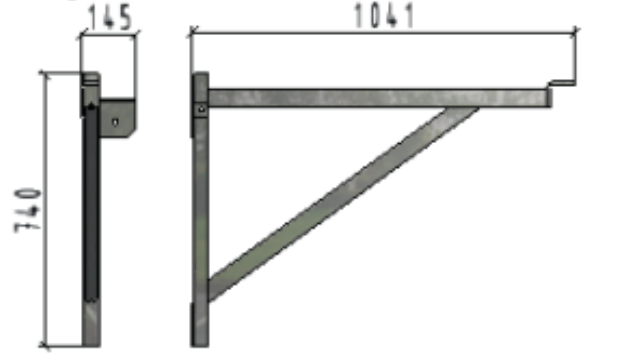
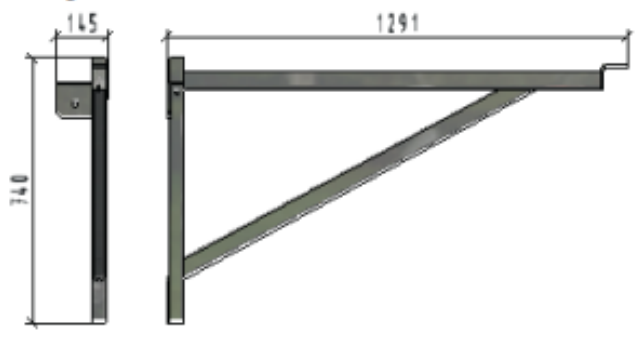
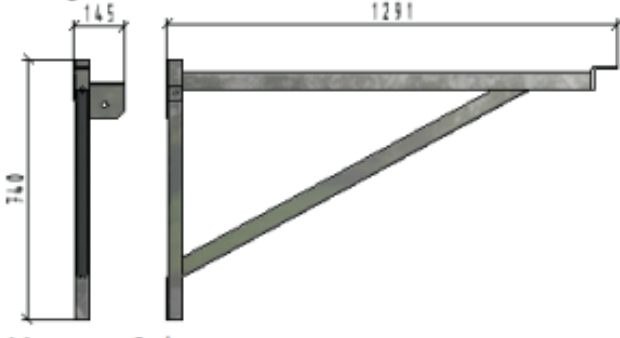


Table 3. Elements necessary to adjust the height of the stairs depending on the dimensions of the containers.

Item	Code	Description	Container H=2591	Container H=2800	Container H=2900
S1	P-SK5-SB-E01	Step	0	1	2
	P-SK5-SB-E01-1200				
A	ISO 4017.	Bolt M10x25 8.8	0	2	4
H	ISO 4032.	Nut M10	0	2	4
K	ISO 7089.	Washer 10	0	4	8

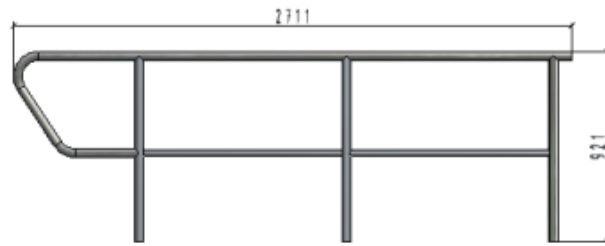
Table 4. Components of the container stairs system.

<p>P-SK5-SB-FD1.1</p>  <p>Mass: 91.030 kg</p>	<p>P-SK5-SB-FG1.1</p>  <p>Mass: 88.232 kg</p>
<p>P-SK5-SB-FD1.2</p>  <p>Mass: 101.431 kg</p>	<p>P-SK5-SB-FG1.2</p>  <p>Mass: 98.633 kg</p>
<p>P-SK5-SB-FR1.1/A</p>  <p>Mass: 11.530 kg</p>	<p>P-SK5-SB-FR1.1/B</p>  <p>Mass: 11.530 kg</p>
<p>P-SK5-PD1.1</p>  <p>Mass: 35.110 kg</p>	<p>P-SK5-PD2.4</p>  <p>Mass: 69.692 kg</p>



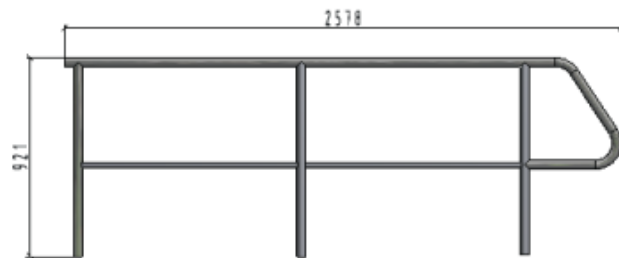
<p>P-SK5-WT-1000-ML</p>  <p>Mass: 9.875 kg</p>	<p>P-SK5-WT-1000-MP</p>  <p>Mass: 9.875 kg</p>
<p>P-SK5-WT-1200-ML</p>  <p>Mass: 11.063 kg</p>	<p>P-SK5-WT-1200-P</p>  <p>Mass: 11.063 kg</p>
<p>P-SK5-PR</p>  <p>Mass: 17.529 kg</p>	
<p>P-SK5-PR2</p>  <p>Mass: 13.645 kg</p>	

P-SK5-BS-1



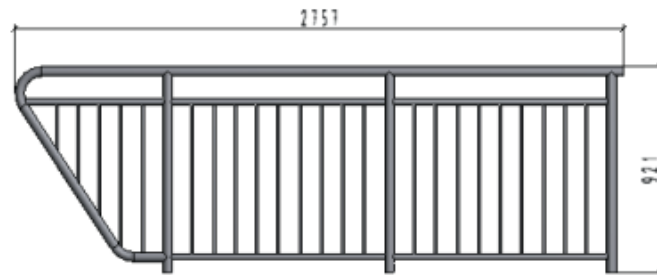
Mass: 17.978 kg

P-SK5-BS-2



Mass: 16.964 kg

P-SK5-BS-B-1

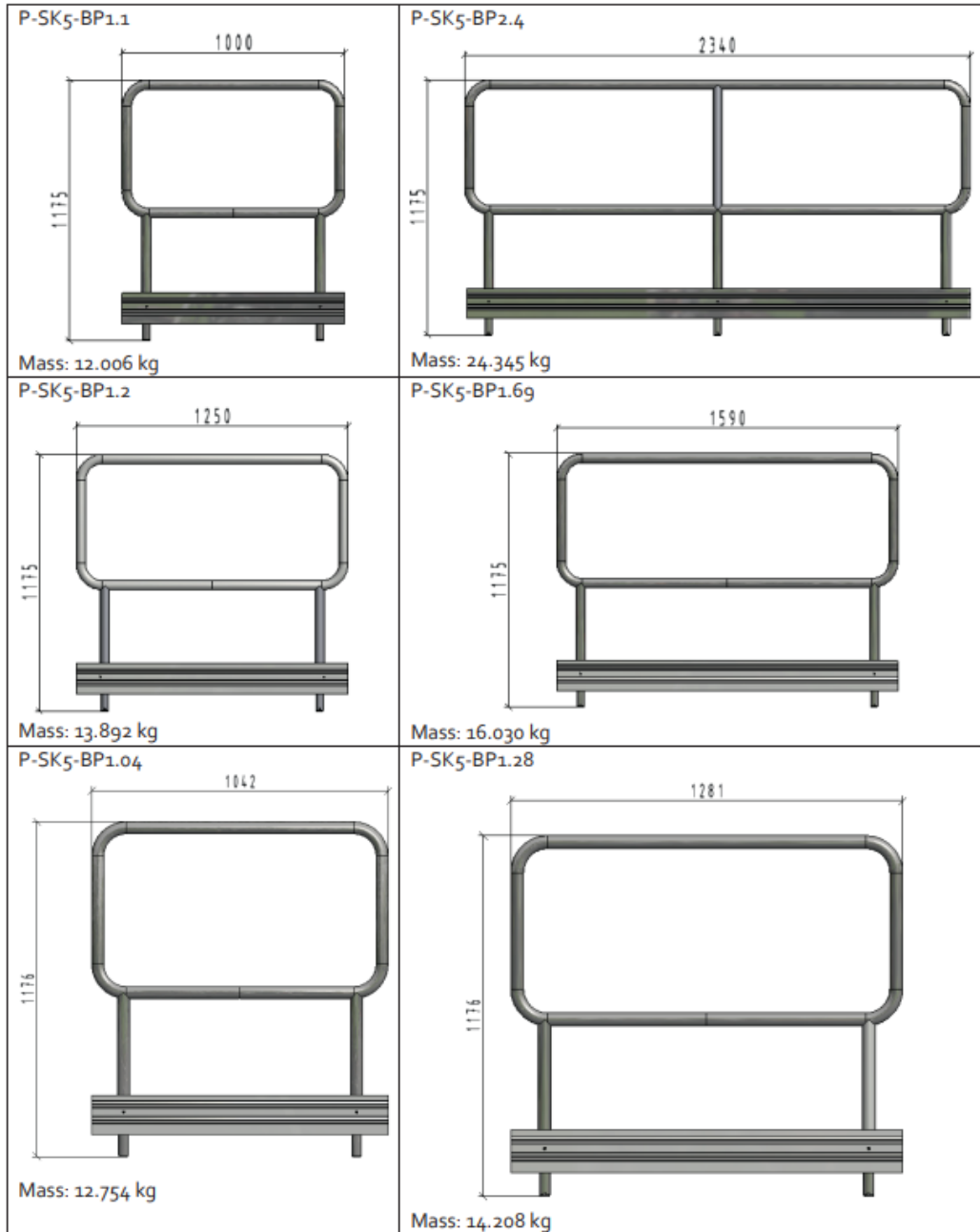


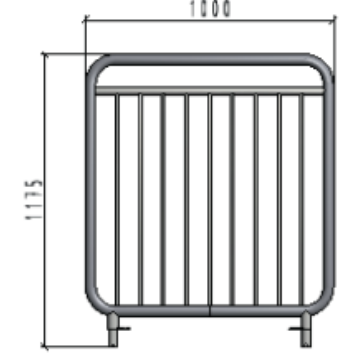
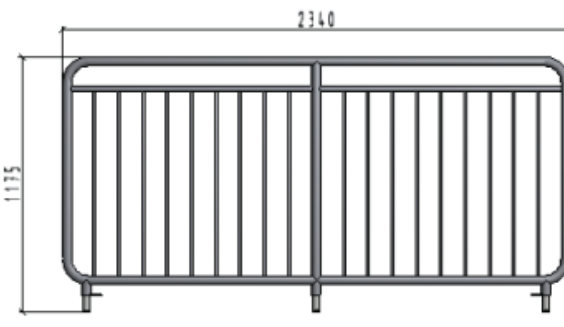
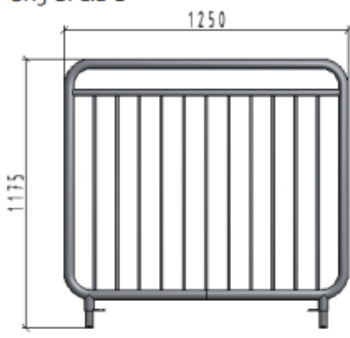
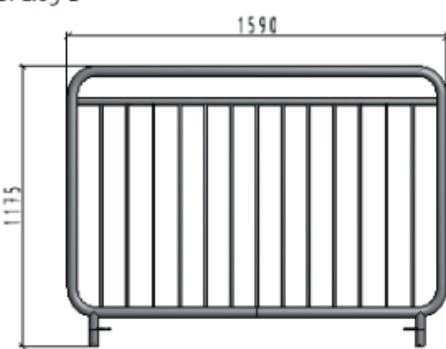
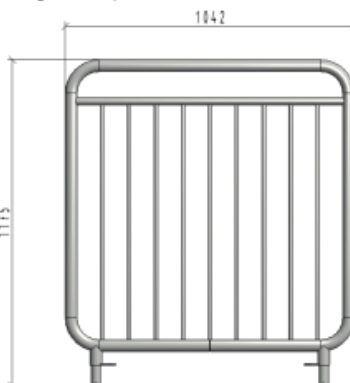
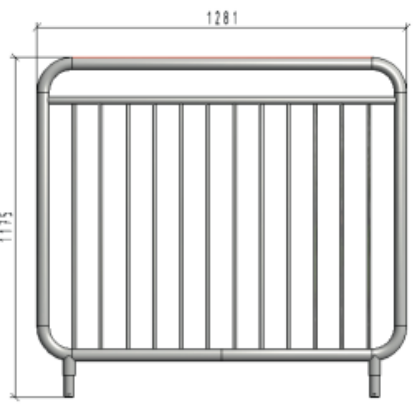
Mass: 33.801 kg

P-SK5-BS-B-2



Mass: 30.703 kg



<p>P-SK5-BP1.1-B</p>  <p>Mass: 17.722 kg</p>	<p>P-SK5-BP2.4-B</p>  <p>Mass: 35.108 kg</p>
<p>P-SK5-BP1.2-B</p>  <p>Mass: 20.632 kg</p>	<p>P-SK5-BP1.69-B</p>  <p>Mass: 24.170 kg</p>
<p>P-SK5-BP1.04-B</p>  <p>Mass: 18.105 kg</p>	<p>P-SK5-BP1.28-B</p>  <p>Mass: 21.745 kg</p>

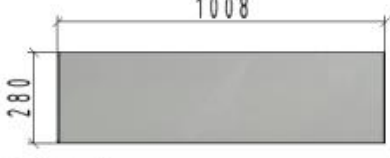
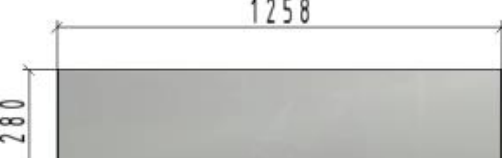
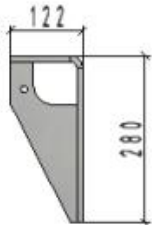
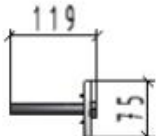
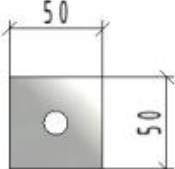
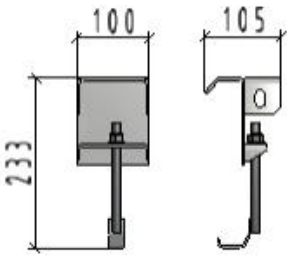
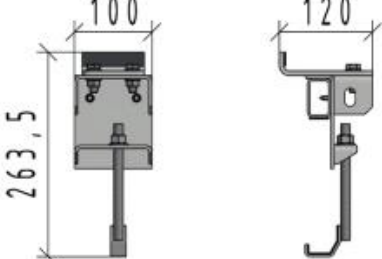




<p>P-SK5-SB-E01</p>	<p>P-SK5-SB-E01-1.2</p>	
 <p>Mass: 6.924 kg</p>	 <p>Mass: 7.958 kg</p>	
<p>P-SK5-LP</p>  <p>Mass: 2.875 kg</p>	<p>ZW</p>  <p>Mass: 0.391 kg</p>	<p>PK</p>  <p>Mass: 0.149 kg</p>
<p>P-SK5-LP2</p>  <p>Mass: 1.107 kg</p>		<p>P-SK5-LP3</p>  <p>Masa: 1,982 kg</p>

Table 5. Lists of tools

	<p>Spanners: 21, 19, 17, 13, 10</p>
	<p>Level</p>
	<p>Measuring tape</p>
	<p>Joist, min. load capacity 1 t</p>

4. Assembly operations with individual elements of the container stairs system.

The assembly instructions present the method of installation of the individual elements of the container stairs system.

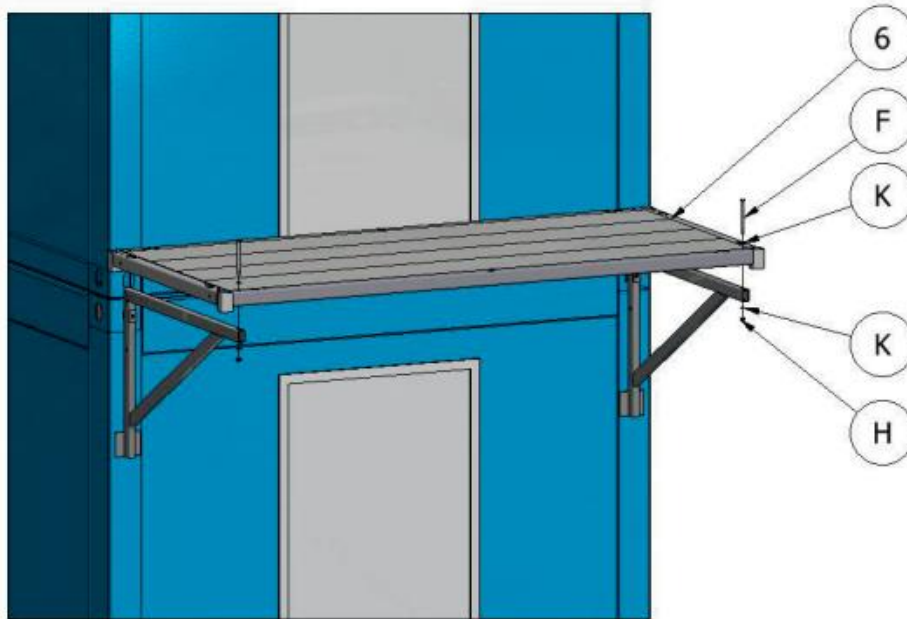
4.1. Assembly: supports

Assembly of supports is done by setting the support clamp in the cell of the container, and then sliding the support and installing it with the washer – nut set.



4.2. Assembly of landings

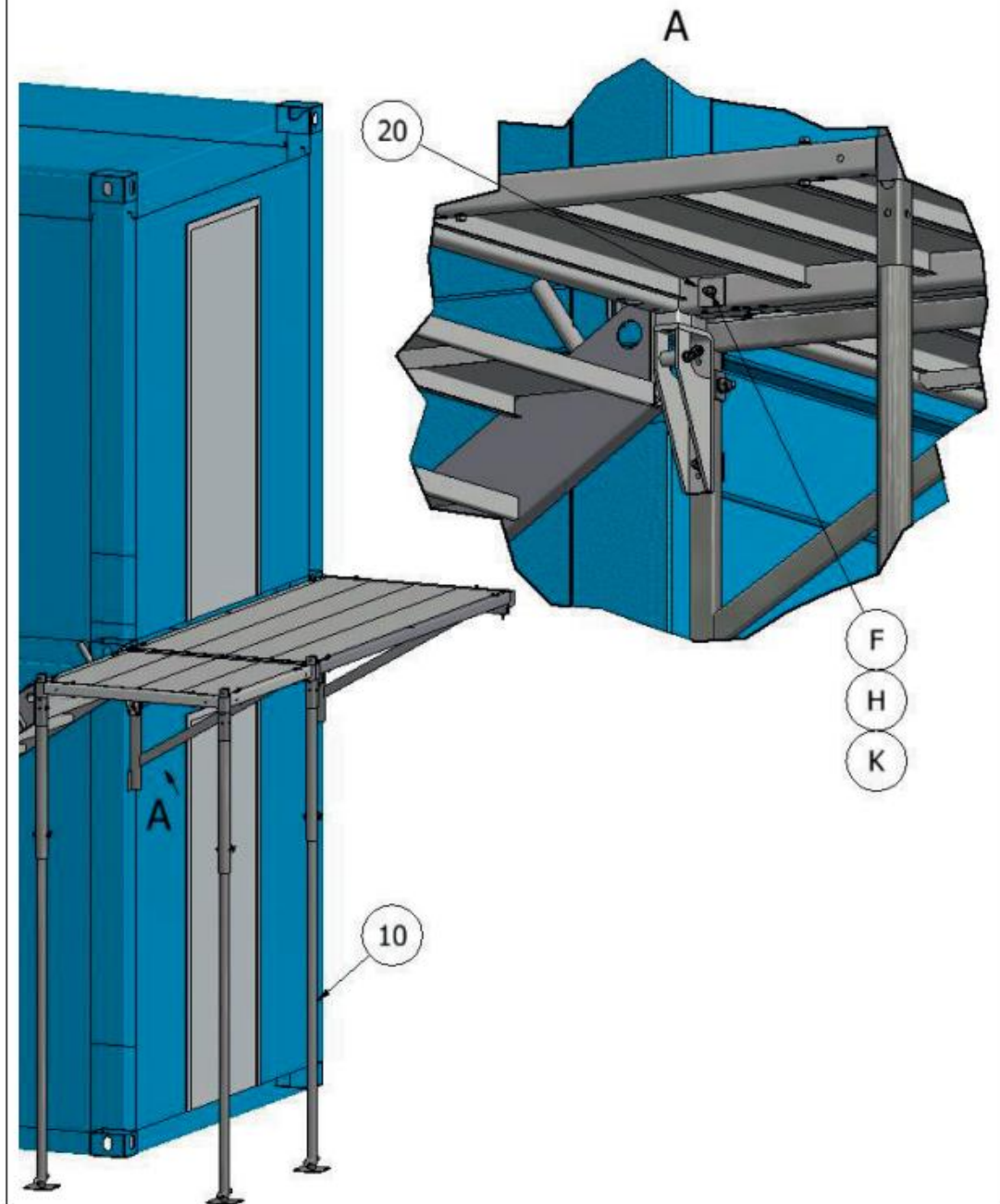
The landings are installed on supports and then fixed with bolt – washer – nut sets.



If stairs are installed to the landing, the landing should be supported on one side with two poles or with a support and a pole.

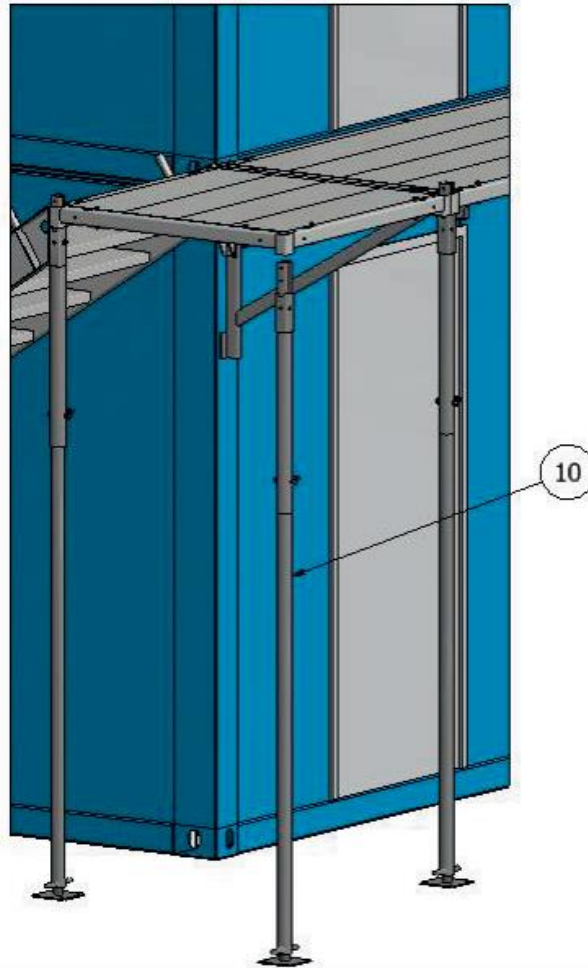


If the landing cannot be set on supports, it should be supported in at least three cells with poles, and fixed to the neighbouring landing installed on supports. The neighbouring platforms should be fixed with each other with the PK pad – bolt – washers – nut sets.



4.3. Assembly: posts

The poles should be set in the cells of the landing.

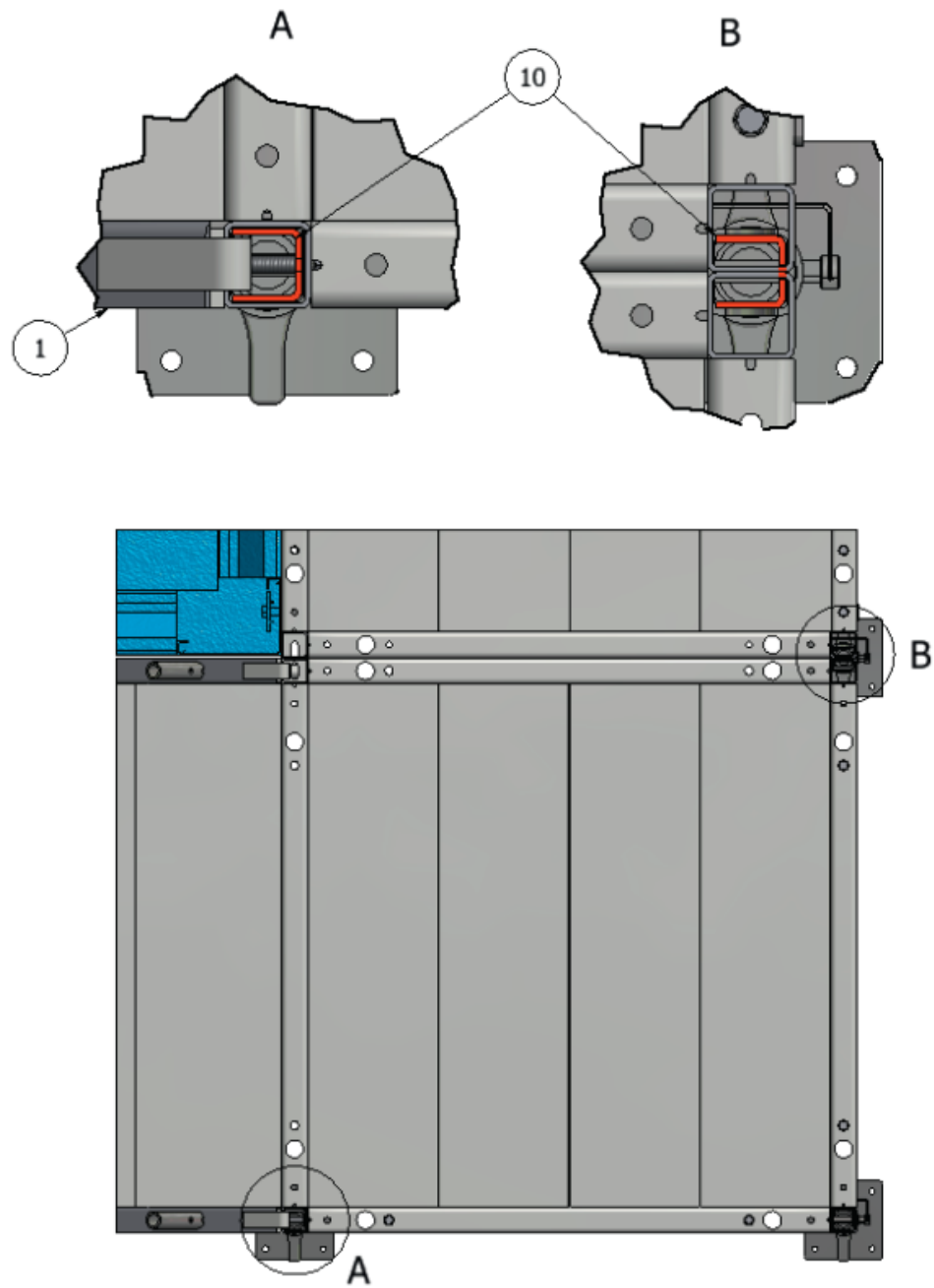


To adjust the poles to the height of the container, they have a 3-step adjustment provided in the upper part. For uneven ground, the height of the post may be additionally adjusted with the adjustable foot.

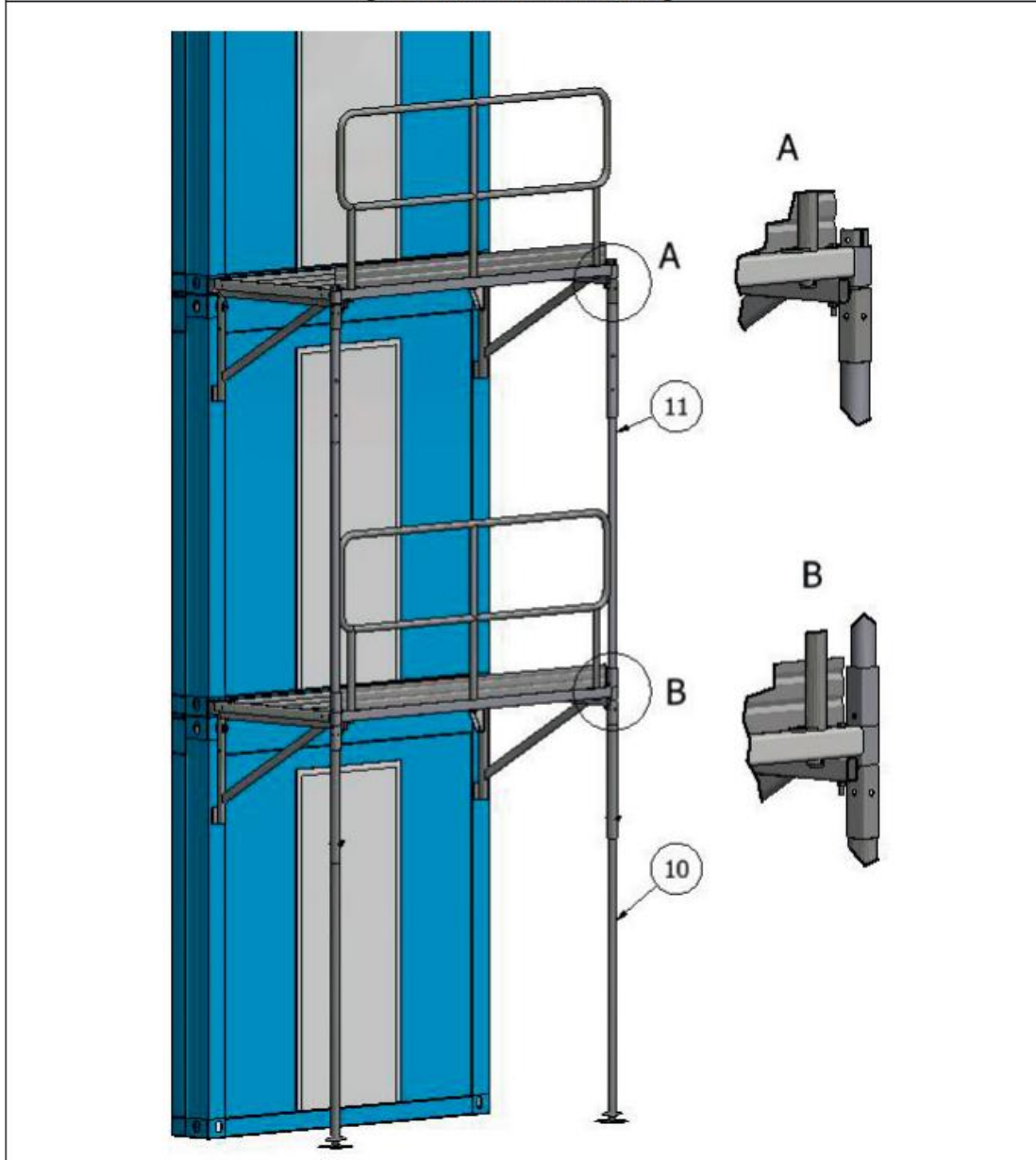


The poles that are installed on the stairs should be assembled so that the opening in the mandrel of the pole faces the hook of the stairs.

Two neighbouring landings should be supported with one pole with the mandrel set in two cells.



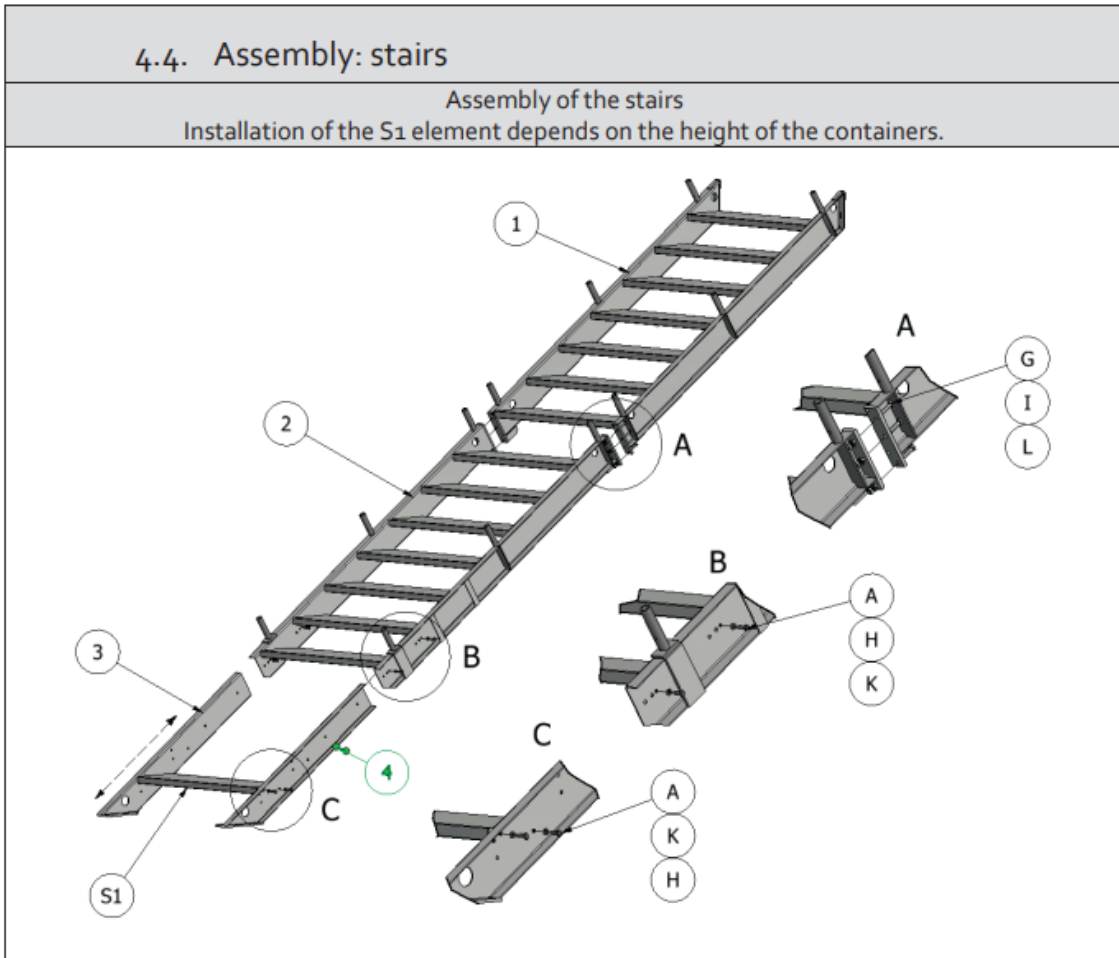
When the container stairs are installed in levels, the landings should be supported with poles from the ground level to the last landing.



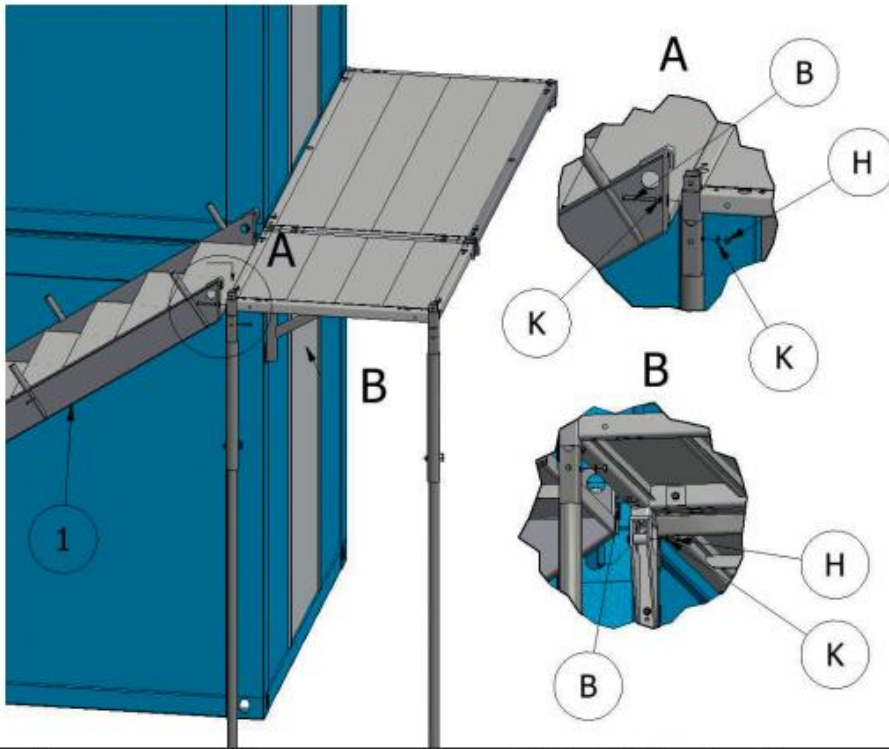
4.4. Assembly: stairs

Assembly of the stairs

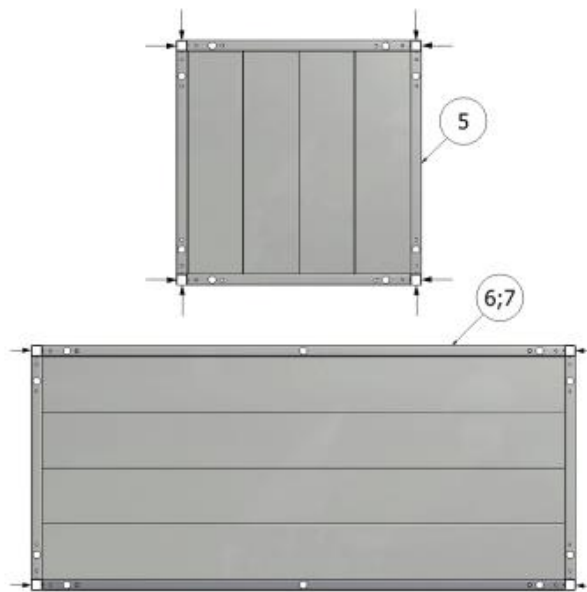
Installation of the S1 element depends on the height of the containers.



suspended on the cells of the landing and then fixed with the bolt – washers – nut set.

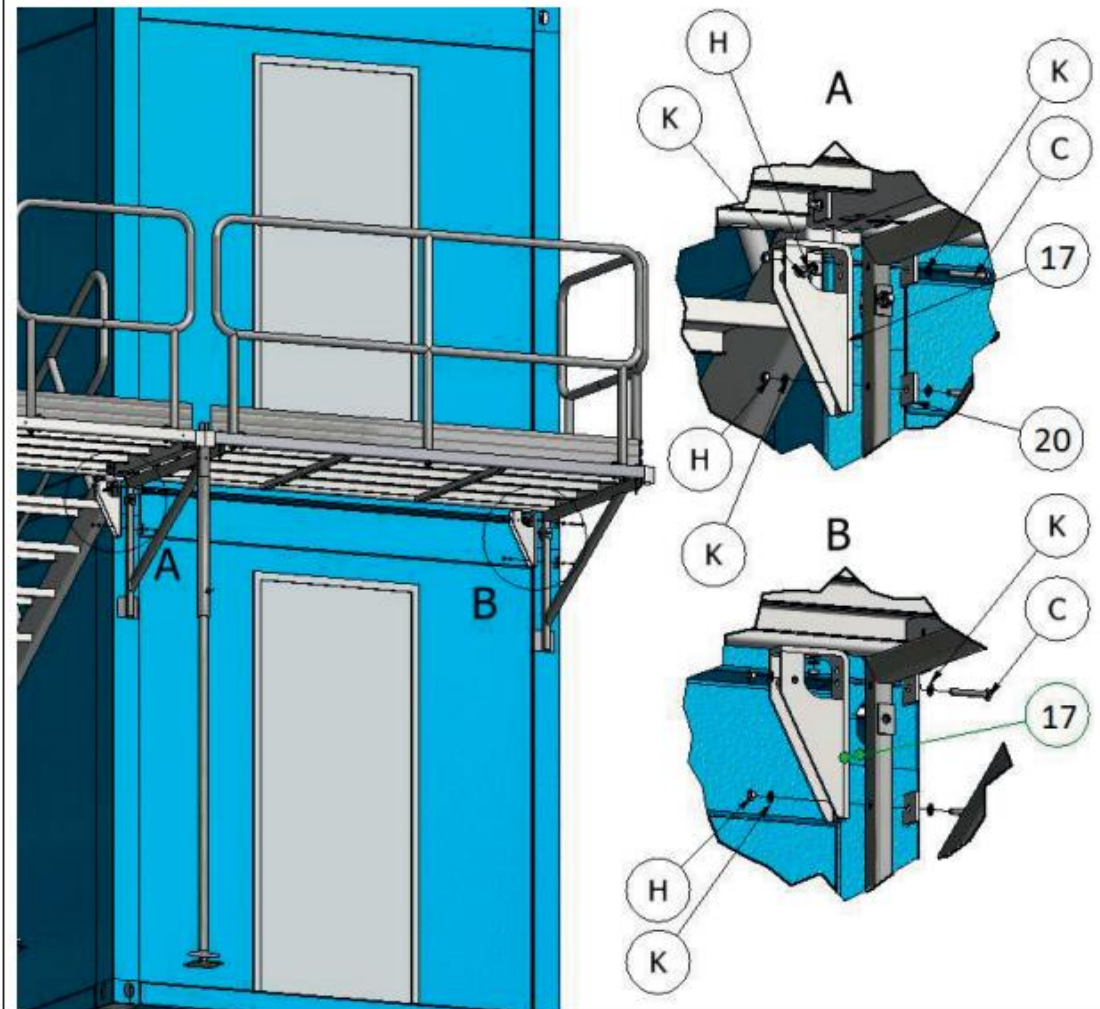


Landings 1100x1100 and 1200x1200 may have stairs installed on four sides, as needed. Landings with the 2440 and 1690 length may have stairs installed only along the shorter edge.



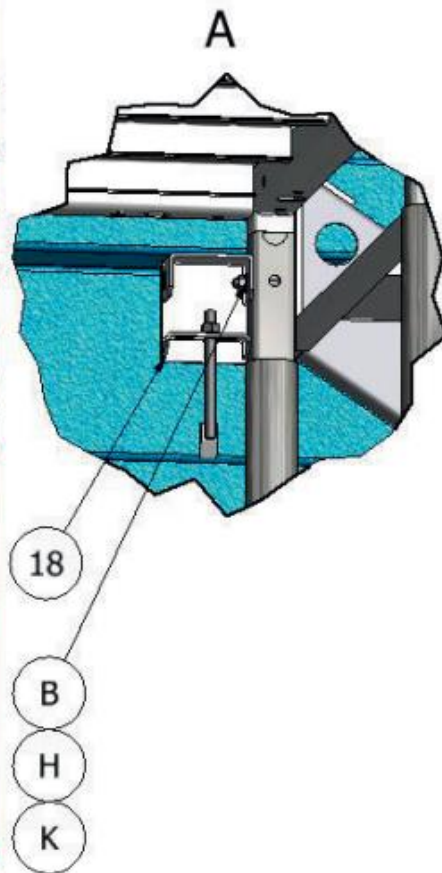
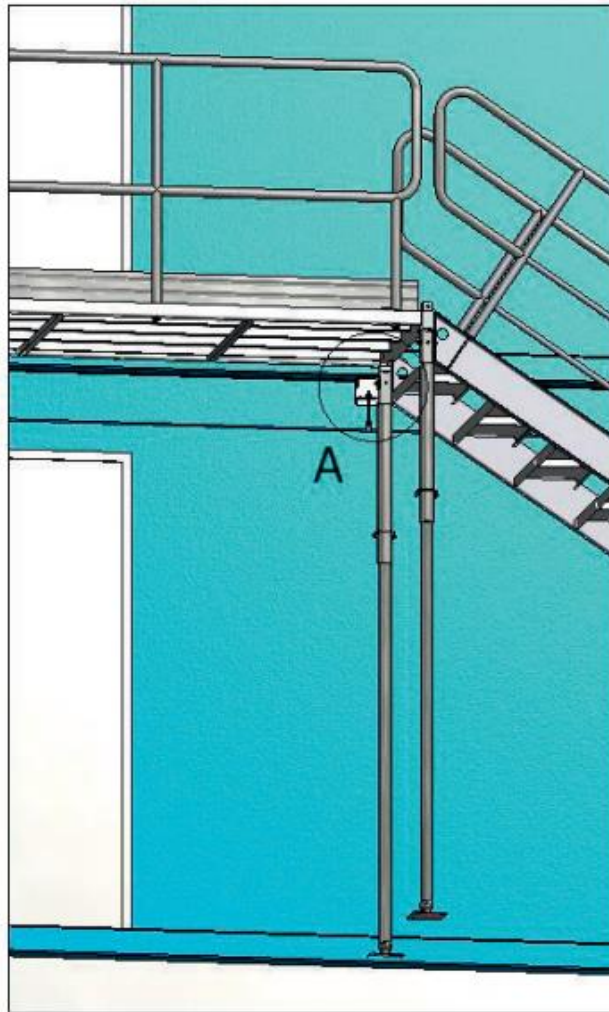
4.5. Assembly: LP connector

The LP connector should be fixed to the support with the bolt – PK pad – washers – nut set.
If the connector is installed in a series of landings, it should be fixed to the support and to the landing.
When the connector is installed on the stairs, it should be fixed to the support and to the stairs.



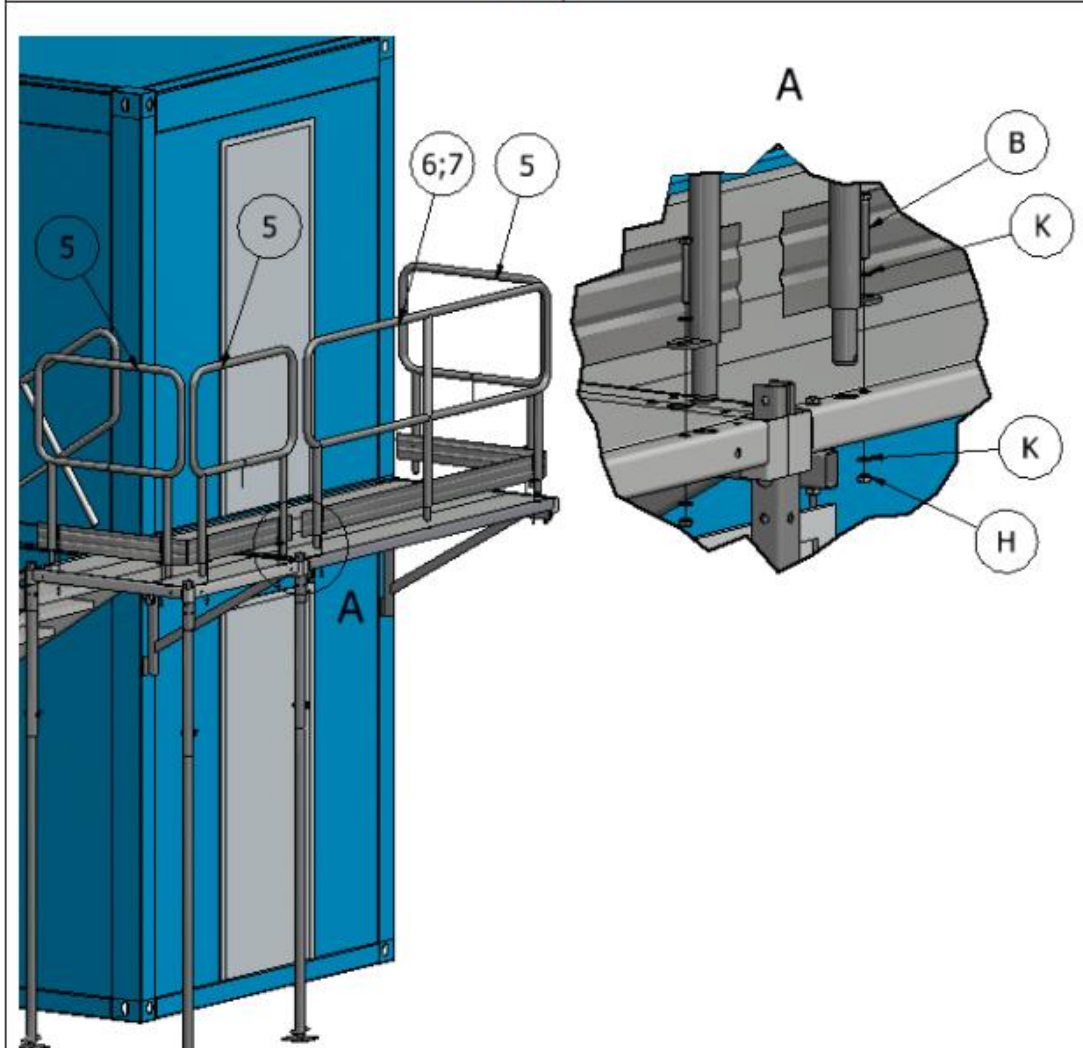
4.6. Assembly: LP2/LP3 connector

The LP2/LP3 connector is installed on the cornice of the container and is fixed to the container stairs structure. It prevents the landing from slipping away from the container when the landing is installed on one support and two poles along the container.



4.7. Assembly: barriers

The barriers are installed by setting in the cells of the landing and fixing to the landing with the bolt – washers – nut set. Optionally, barriers have openings in order to be secured with cotter pins.



Stair barriers are installed by setting on stair mandrels and securing with the bolt – nut sets.

